

# DVR-TV-Out Matrix

Installation Guide

Rev 1.5

Digital Video Security System  
Digital Video Recorder

[WWW.CCTVONE.COM](http://WWW.CCTVONE.COM)

**CCTVONE.**

\*All contents of this document may change without prior notice, and actual product appearance may differ from depicted herein.

# Index

- 1. TV-OUT Matrix Features** ..... 3
- 2. Products and Components** ..... 4
  - 2-1. DVR TV-OUT Matrix Board ..... 4
  - 2-2. Accessories ..... 4
  - 2-3. Optional Accessories ..... 4
- 3. Board Layout** ..... 5
  - 3-1. DVR TV-OUT Matrix Master Board ..... 5
  - 3-2. DVR TV-OUT Matrix Slave Board ..... 6
- 4. Board Installation** ..... 7
  - 4-1. TV OUT Matrix – 16 Channel Inputs for ACAP, LIVCAP Series (w/ Master Board) ..... 7
  - 4-2. TV OUT Matrix – 16 Channel Inputs for AMX, D1 Series (w/ Master Board) ..... 8
  - 4-3. TV OUT Matrix – 16 Channel Inputs for ACAP, LIVCAP Series (w/ Master & Slave Board) ..... 9
  - 4-4. TV OUT Matrix – 16 Channel Inputs for AMX, D1 Series (w/ Master & Slave Board) ..... 10
  - 4-5. TV OUT Matrix – 32 Channel Inputs for LIVCAP Series (w/ Master & Slave Board) ..... 11
  - 4-6. TV OUT Matrix – 32 Channel Inputs for AMX Series (w/ Master & Slave Board) ..... 12
  - 4-7. TV OUT Matrix – 16 Channel Inputs for ACAP, LIVCAP Series (w/ Back Panel) ..... 13
  - 4-8. TV OUT Matrix – 16 Channel Inputs for AMX, D1 Series (w/ Back Panel) ..... 15
- 5. Software Installation** ..... 16
  - 5-1. Driver Installation ..... 16
  - 5-2. Program Installation ..... 17
- 6. TV-OUT** ..... 18
  - 6-1. TV-OUT Interface ..... 18
  - 6-2. TV-OUT Ports ..... 18
  - 6-3. Menu ..... 19
  - 6-4. Setup ..... 20
    - 6-4-1. General ..... 20
    - 6-4-2. TV1, TV2, TV3, TV4 ..... 21

## Preface

DVR (Digital Video Recorder) technology replaces the use of existing analog technology, like VHS tapes and VCR's, by being able to store images in digital formats that are superior in both convenience and quality.

One of the many problems with analog tapes is the limited searching capabilities they provide. Searching for a certain event or time period in an analog tape is both tedious and inefficient. Now, with the introduction of DVR, it has become easier, among other things, to find the images you want: simply enter the time and date into the computer and data is retrieved in seconds. No more mundane searches or manual tracking of tapes.

With VCRs, preservation of recorded data, especially sensitive recordings, was difficult to do. DVR provides several options (DAT, CD, DVDs) in permanently preserving large amounts of data in digital formats, maintaining the integrity of the video for far longer periods than any analog tape.

The DVR also works in conjunction with sensors to operate security systems: relays can close shutters or ring sirens when motion sensors are triggered, for instance.

In addition, our DVR makes it possible to modify DVR settings and retrieve recorded data remotely through a network or the Internet.

Reliability, convenience in searching and storing, and flexibility to meet various demands for surveillance systems are what make us proud in offering the next generation DVRs.

Various features briefly introduced here are just some of the features of a constantly evolving technology.

We are always striving to innovate and create new ideas to meet demands from all areas of the globe.

E-mail: [support@cctvone.com](mailto:support@cctvone.com)

Tel: 323-721-8999

Fax: 323-721-8599

[www.cctvone.com](http://www.cctvone.com)

# 1. TV-OUT Matrix Features

- Support up to 4 independent TV-OUTs for displaying spot images from DVR capture board.
- Support up to 32 camera inputs.

Feature	Description
Camera Input	1~16 (32 optional) Ports (NTSC/PAL)
TV Output	2 ports (4 ports optional)
TV Monitor Layout	Port 1: support up to 16 screen divisions. Port 2: support 1 and 4 screen divisions. Port 3 (Optional): support up to 16 screen division. Port 4 (Optional) : support 1 and 4 screen division.
Compatible Capture models	120A16, 120N16, 240N16, 240N32, 480N32, 12016LIV, 24016LIV, 48016AMX, 96032AMX, 48016D1

\* 4 Ch. TV-OUT consists of Master & Slave TV-OUT matrix boards.

## 2. Products and components

### 2-1. DVR TV-OUT Matrix Board



DVR TV-OUT Matrix – Master Board



DVR TV-OUT Matrix – Slave Board (Optional)

### 2-2. Accessories



Video Cable



Master to Slave connection cable

### 2-3. Optional Accessories



Back Panel Video Cable

## 3. Board Layout

### 3-1. DVR TV-OUT Matrix Master Board

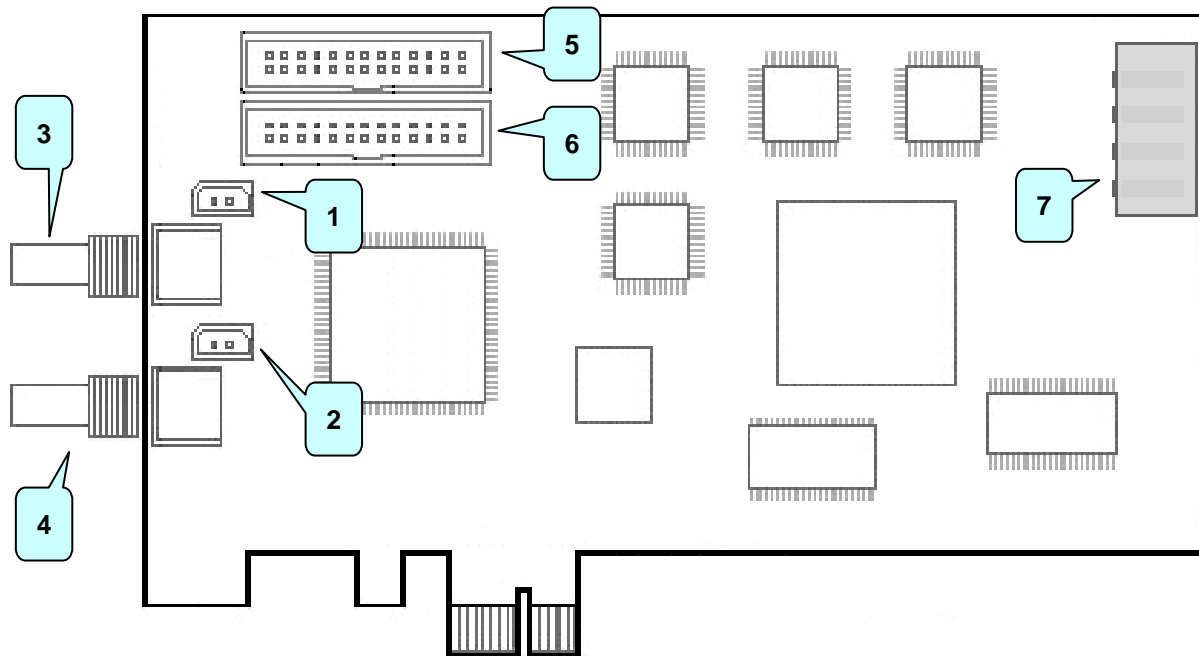

**Master Board**

1. Composite OUT Connection Port 1: Connect to the TV-OUT port on Back Panel.
2. Composite OUT Connection Port 2: Connect to the TV-OUT port on Back Panel.
3. Composite OUT Port 2: Connect Composite Monitor
4. Composite OUT Port 1: Connect Composite Monitor
5. Video I/O Port : Connect Capture board
6. Video I/O Port : Connect Capture board (or connect Slave TV-OUT Board)
7. Power : Connect Power

### 3-2. DVR TV-OUT Matrix Slave Board

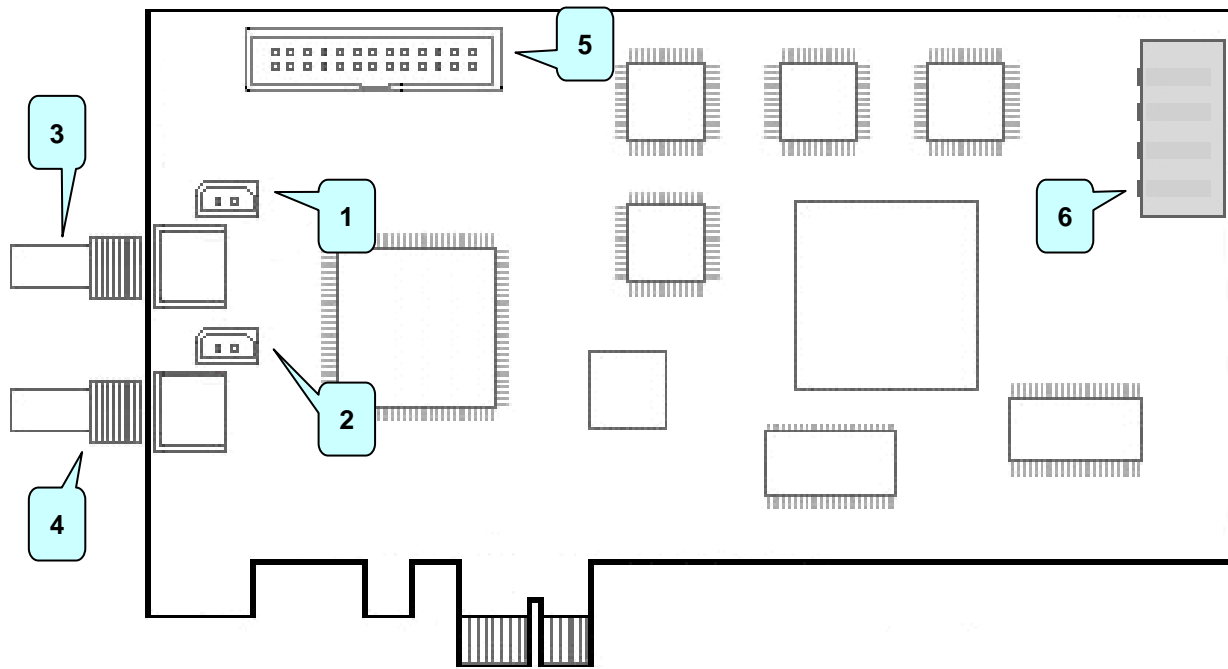

**Slave Board**

1. Composite OUT Connection Port 1: Connect to the TV-OUT port on Back Panel.
2. Composite OUT Connection Port 2: Connect to the TV-OUT port on Back Panel.
3. Composite OUT Port 2: Connect Composite Monitor.
4. Composite OUT Port 1: Connect Composite Monitor.
5. Video I/O Port: Connect Capture board (or connect Master TV-OUT Board).
6. Power: Connect Power.

## 4. Board Installation

### 4-1. TV-OUT Matrix – 16 Channel Inputs for ACAP, LIVCAP Series (w/ Master Board)

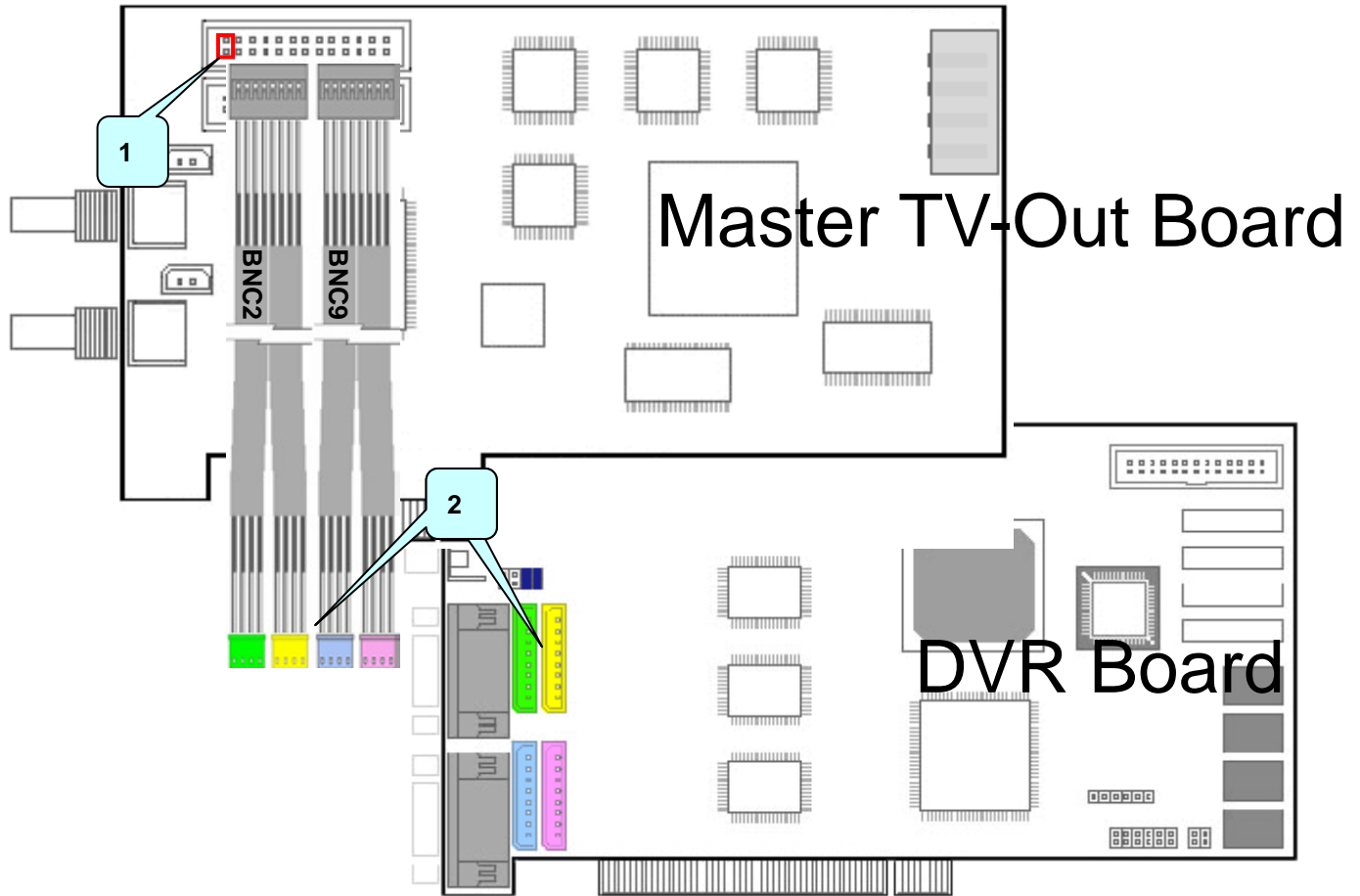

1. Connect the video cable to the Video Port; make sure to leave the left-most pin and have the black cables facing upward.
2. Connect the other side of the video cable to the Video Port on DVR Capture Board.

**Note:** Wrong cable connection may cause the images to be displayed incorrectly.



## 4-2. TV-OUT Matrix – 16 Channel Inputs for AMX, D1 Series (w/ Master Board)

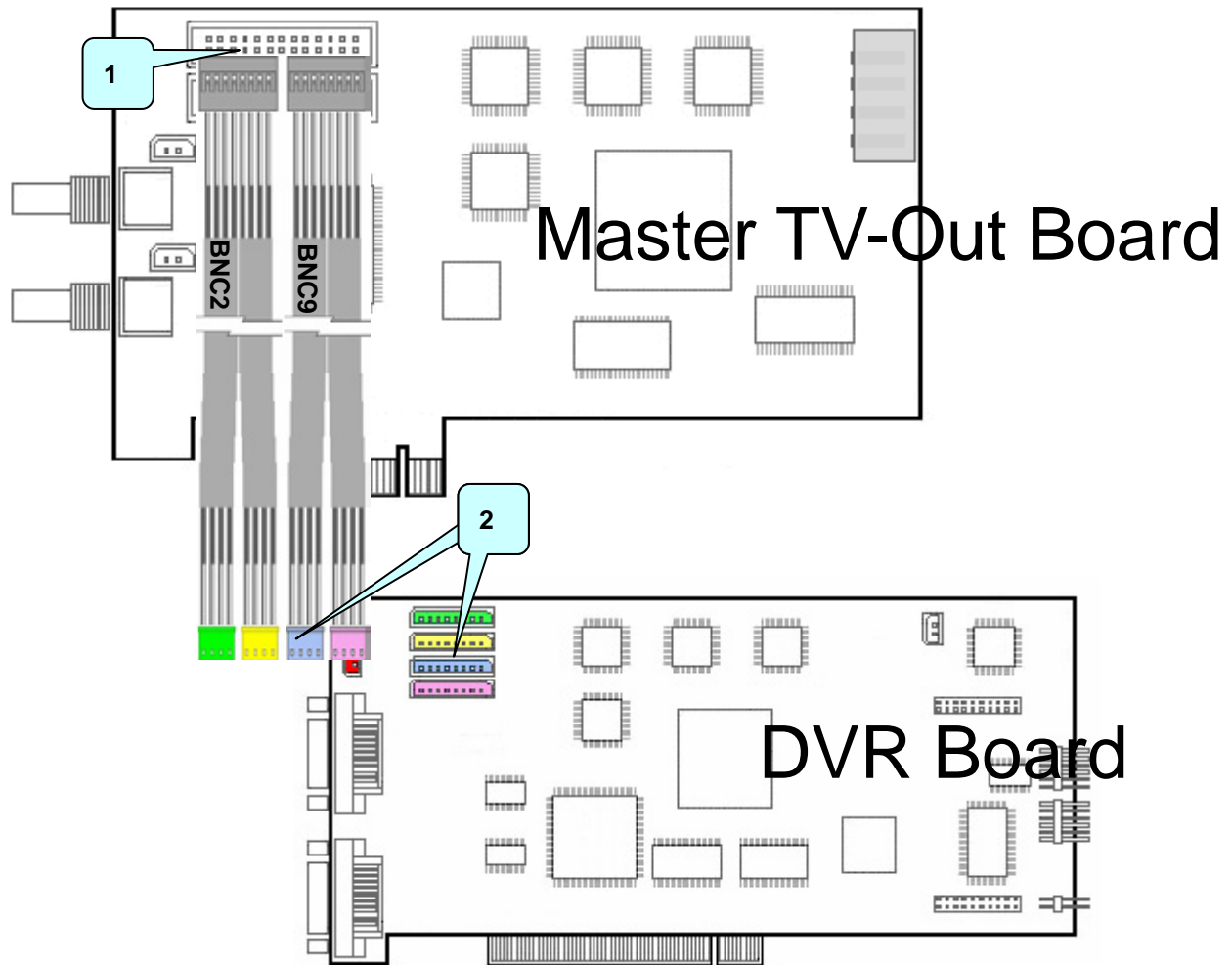

1. Connect the video cable to the Video Port; make sure to leave the left-most pin and have the black cables facing upward.
2. Connect the other side of the video cable to the Video Port on DVR Capture Board.

**Note: Wrong cable connection may cause the images to be displayed incorrectly.**

### 4-3. TV-OUT Matrix – 16 Channel Inputs for ACAP, LIVCAP Series (w/ Master & Slave)

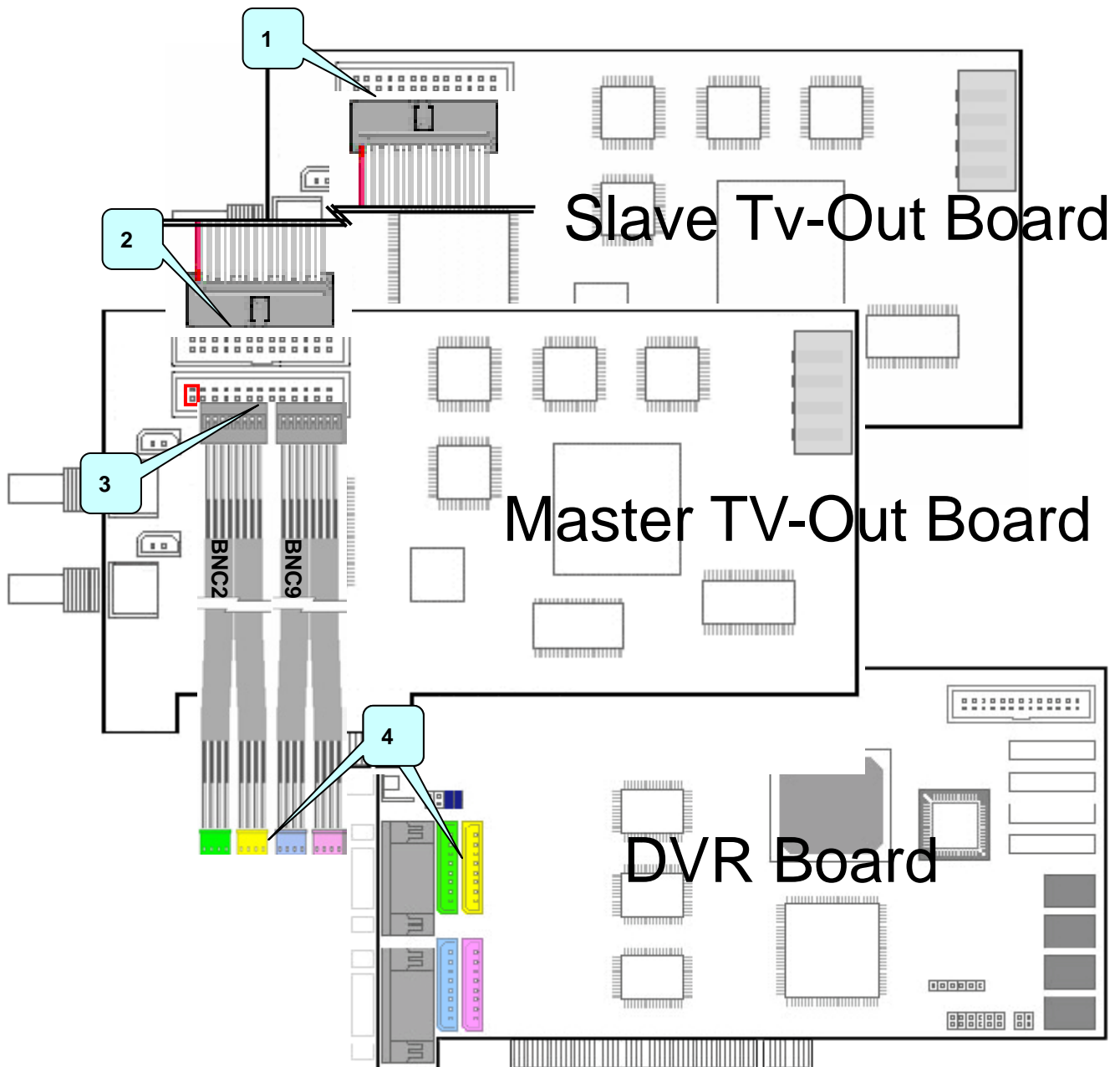

1. Connect the ribbon cable to the Video Port on Slave TV-OUT Board.
2. Connect the ribbon cable to the Video Port on Master TV-OUT Board.
3. Connect the video cable to the Video Port on Master TV-OUT Board with black cables facing upward.
4. Connect the other side of the video cable to the Video Port on DVR Capture Board.

**Note: Wrong cable connection may cause the images to be displayed incorrectly.**

#### 4-4. TV-OUT Matrix – 16 Channel Inputs for AMX, D1 Series (w/ Master & Slave)

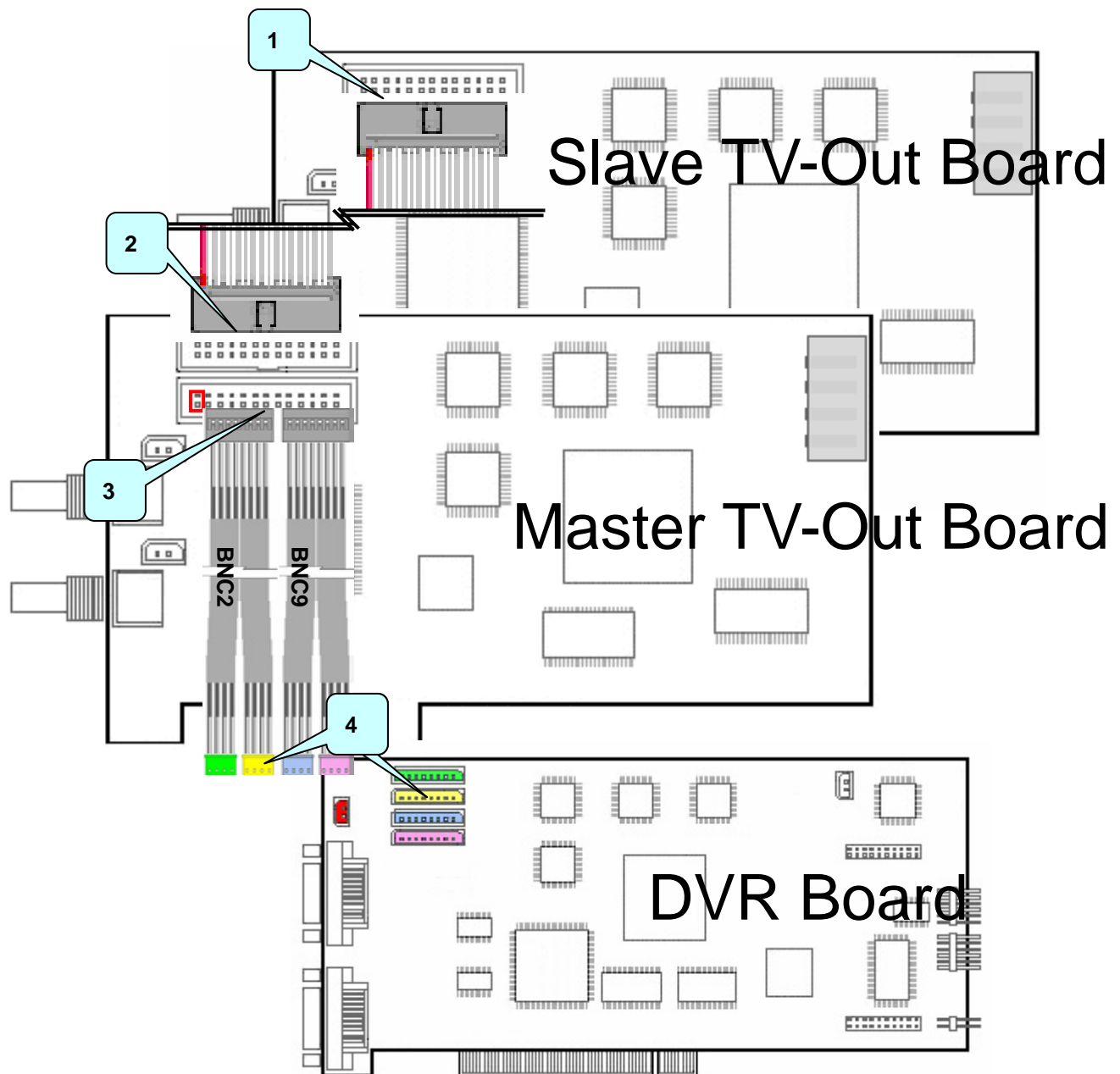

1. Connect the ribbon cable to the Video Port on Slave TV-OUT Board.
2. Connect the ribbon cable to the Video Port on Master TV-OUT Board.
3. Connect the video cable to the Video Port on Master TV-OUT Board with black cables facing upward.
4. Connect the other side of the video cable to the Video Port on DVR Capture Board.

**Note: Wrong cable connection may cause the images to be displayed incorrectly.**

## 4-5. TV-OUT Matrix – 32 Channel Inputs for LIVCAP Series (w/ Master & Slave)

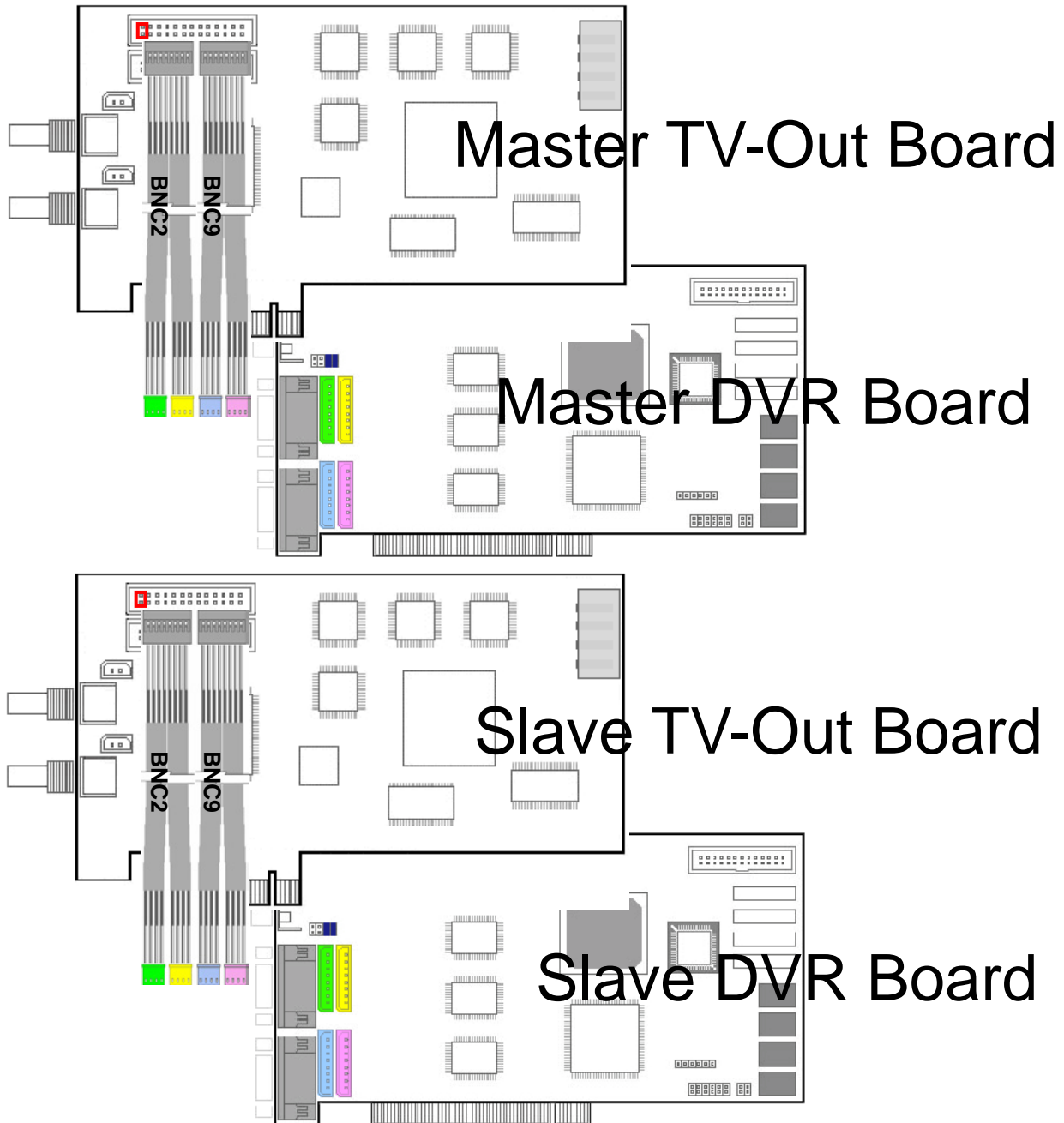

Connect Master TV-OUT Board to Master Capture Board and Slave TV-OUT Board to Slave Capture Board  
(Refer to 4-1 for cable connection diagram for details)

## 4-6. TV-OUT Matrix – 32 Channel Inputs for AMX Series (w/ Master & Slave)

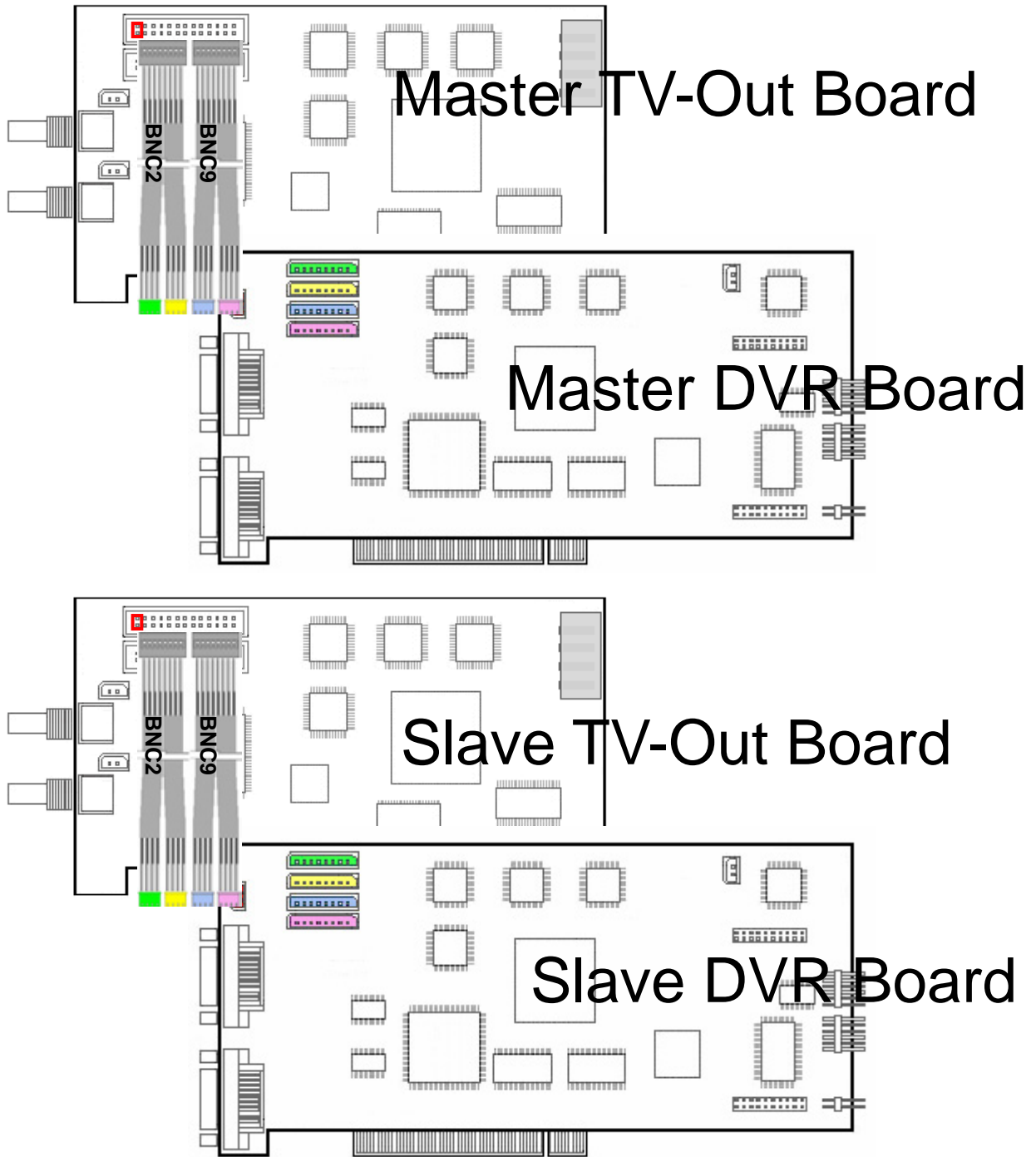

Connect Master TV-OUT Board to Master Capture Board and Slave TV-OUT Board to Slave Capture Board  
(Refer to 4-1 for cable connection diagram for details)

### 4-7. TV-OUT Matrix –16 Channel Inputs for ACAP, LIVCAP Series (w/ Back Panel)

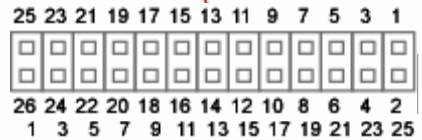
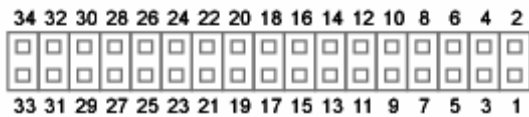
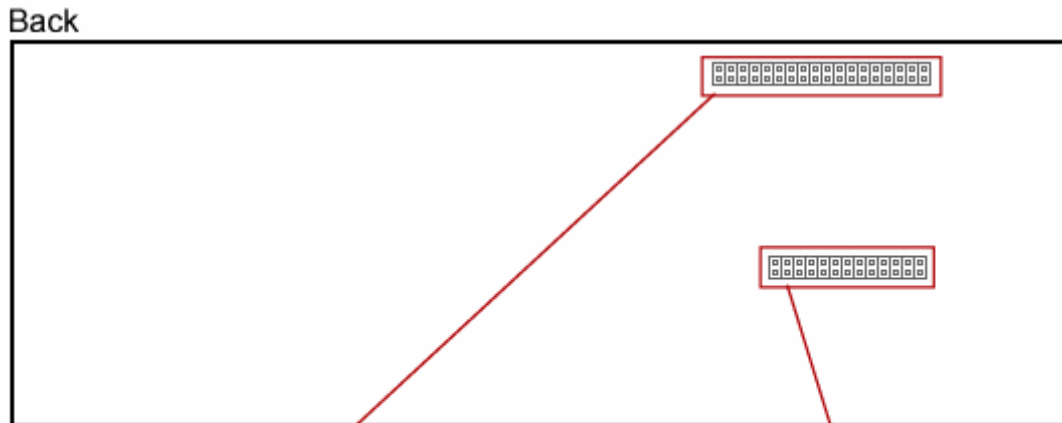
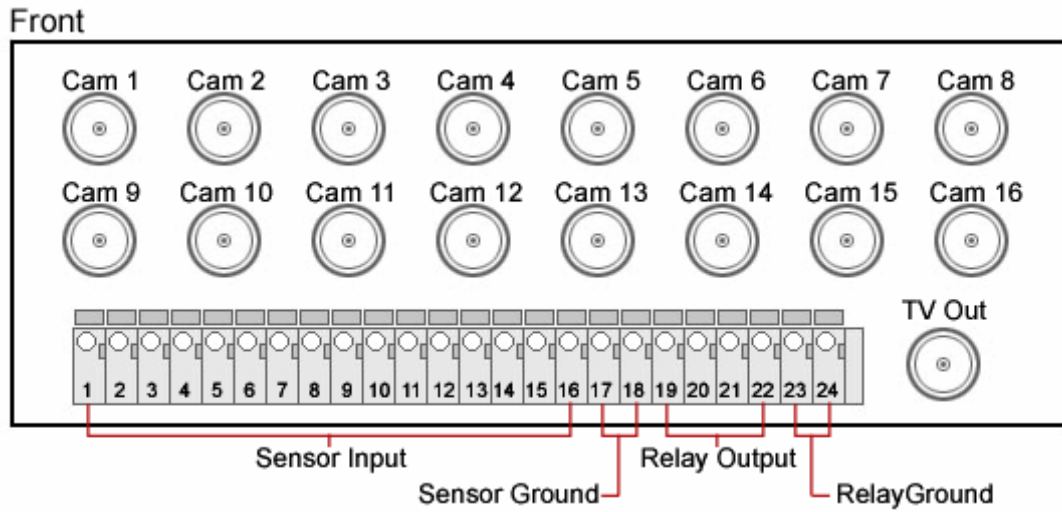

Camera I/O	
Camera Ground	3, 5, ~ 31, 33
Camera Signal	4, 6, ~ 32, 34
TV Out Ground	1
TV Out Signal	2

Sensor & Relay (Digital I/O)	
Sensor Input 0~15	1~16
Input Common 0~1	17, 18
Relay Output 0~3	19~22
Output Common 0~1	23, 24

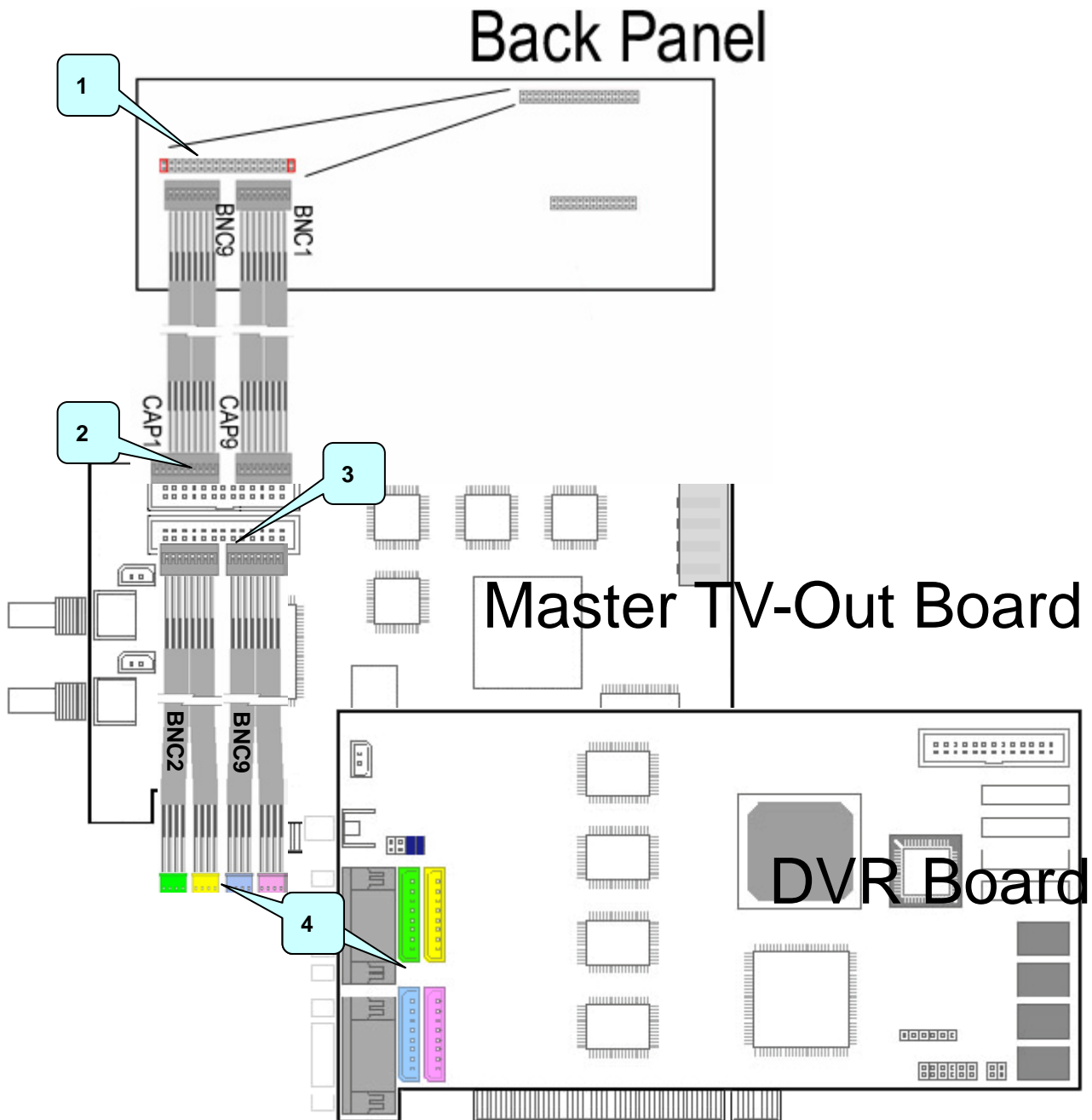

1. Connect the BNC cable to the Back Panel. Make sure to leave the both side pin and have the white cables facing upward.
2. Connect the other side of BNC cable to the Video Port on Master TV-OUT Board.
3. Connect the video cable to the Video Port on Master TV-OUT Board with black cables facing upward.
4. Connect the other side of the video cable to the Video Port on DVR Capture Board.

## 4-8. TV-OUT Matrix –16 Channel Inputs for AMX, D1 Series (w/ Back Panel)

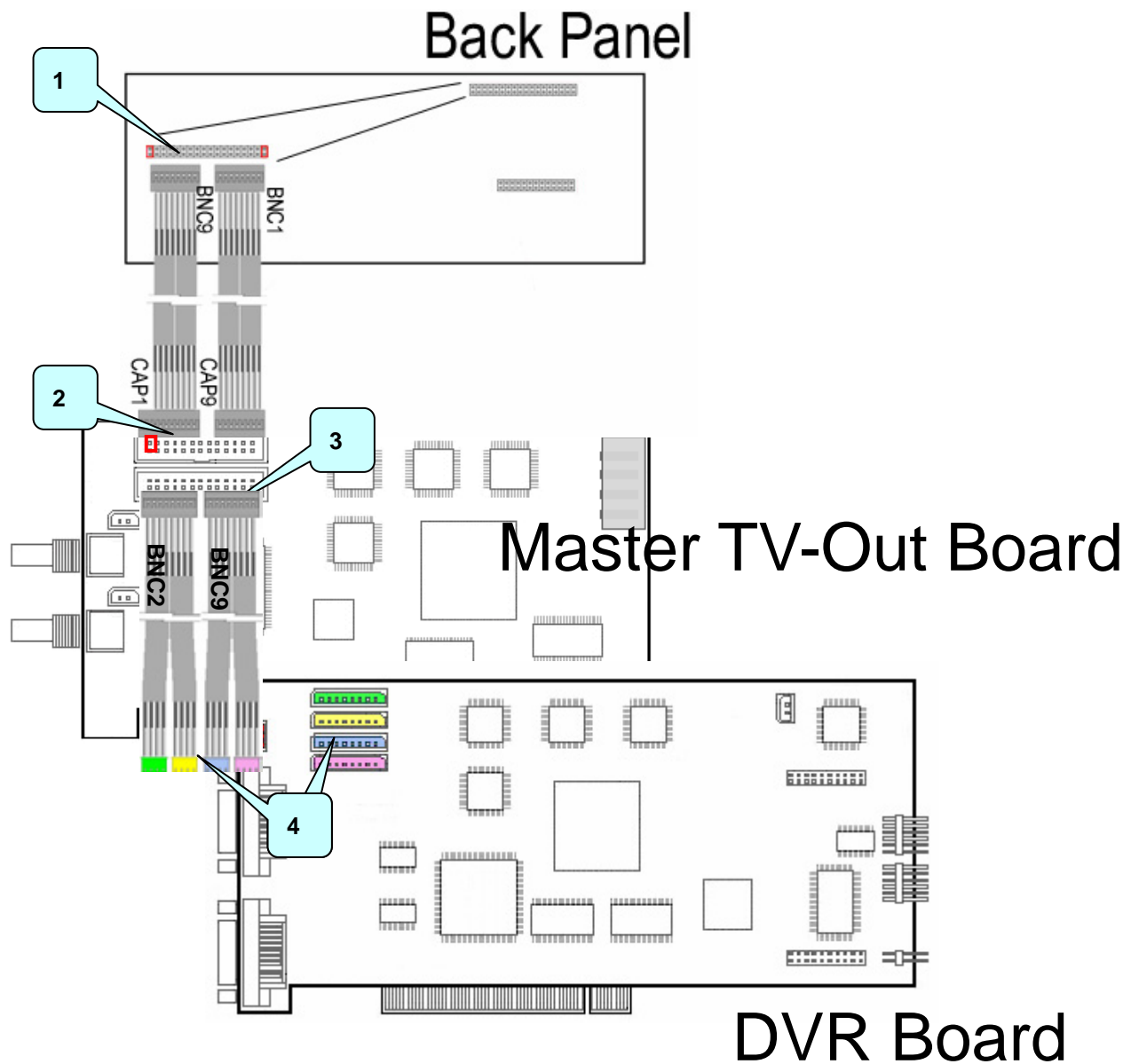

1. Connect the BNC cable to the Back Panel. Make sure to leave the both side pin and have the white cables facing upward.
2. Connect the other side of BNC cable to the Video Port on Master TV-OUT Board.
3. Connect the video cable to the Video Port on Master TV-OUT Board with black cables facing upward.
4. Connect the other side of the video cable to the Video Port on DVR Capture Board.



## 5. Software Installation

### 5-1. Driver Installation

The Hardware Wizard will appear as below when the system detects the TV-Out Matrix board.



Click "Cancel" to install the driver manually.

Open the folder which contains the installation driver and run "Installer.exe"

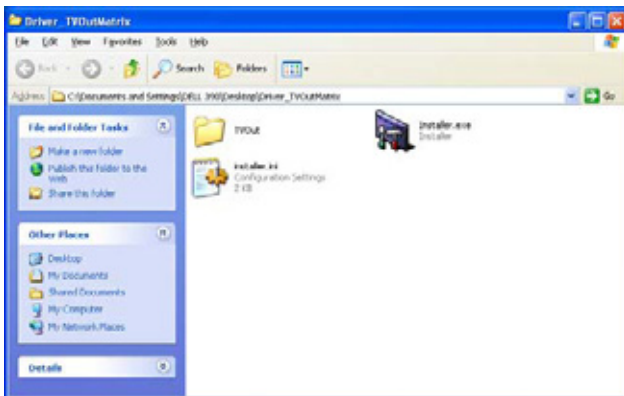

"Installer.exe" will show the list of new devices found on the system.

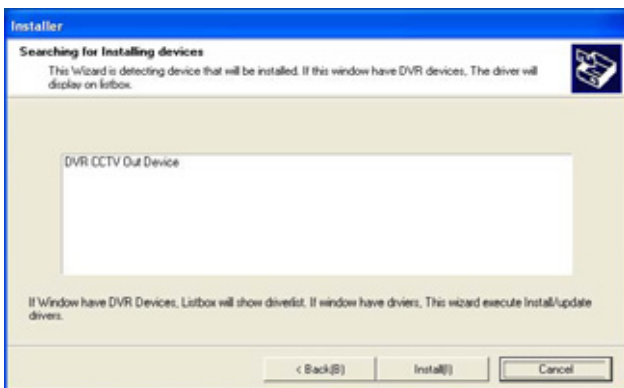

Click "Install" to continue

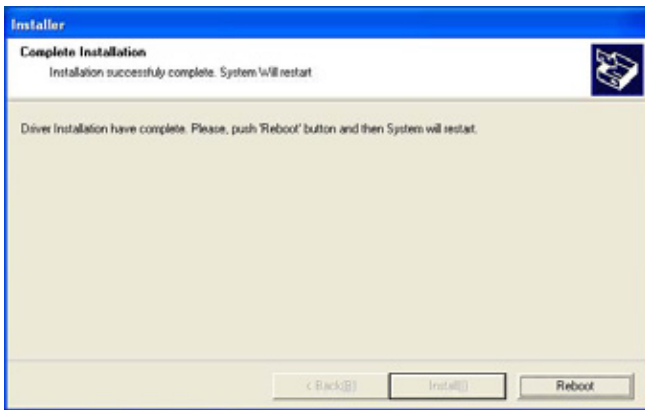

Click "Reboot" to restart the system. It is required to restart the system to complete the installation process.

## 5-2. Program Installation

Open the folder containing the installation program and run 'TVOutMatrix\_v11110.exe'.

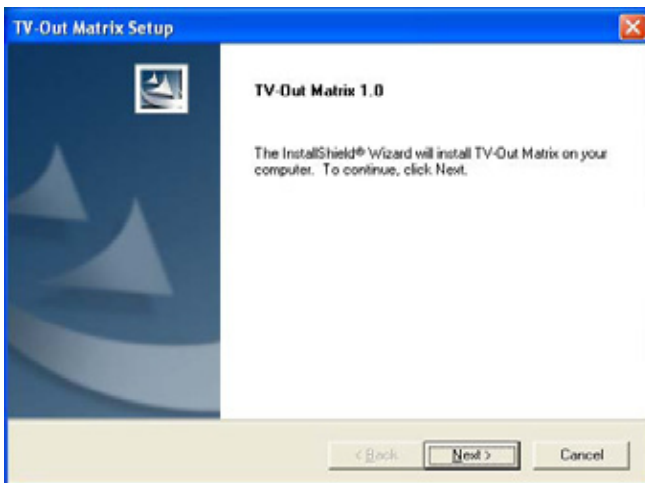

Click "Next" to continue

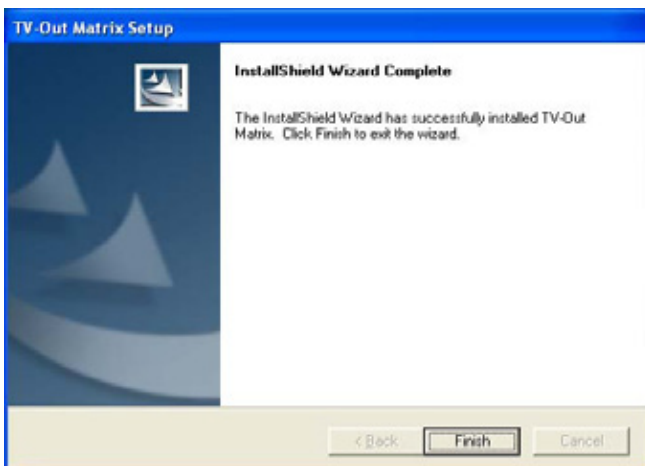

Click "Finish" to finish installation

## 6. TV-OUT

### 6-1. TV-OUT Interface

Click "TV-OUT" button on the DVR Main GUI, then the TV-OUT Control window will appear as below.

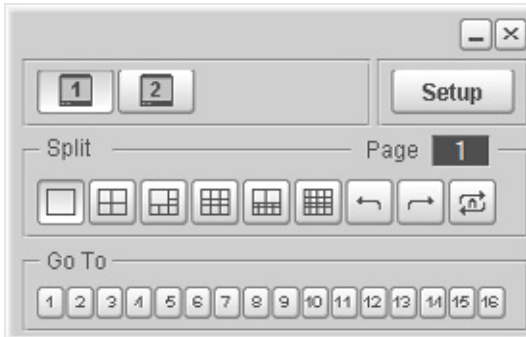

TV-OUT Master Board only

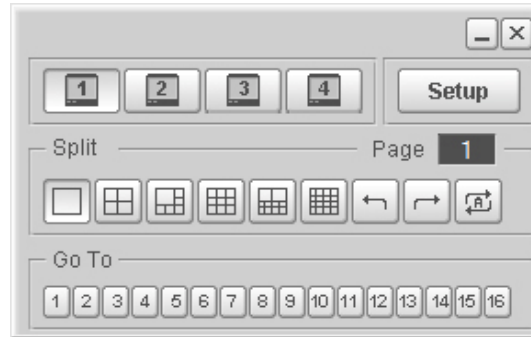

TV-OUT Master & Slave Board

**NOTE :** There will be 2 TV-OUT ports available for a single TV-Out Master board and 4 TV-OUT buttons for two TV-Out Matrix Boards (Master & Slave).

### 6-2. TV-OUT ports

Split screens for each TV-OUT ports are shown as below.

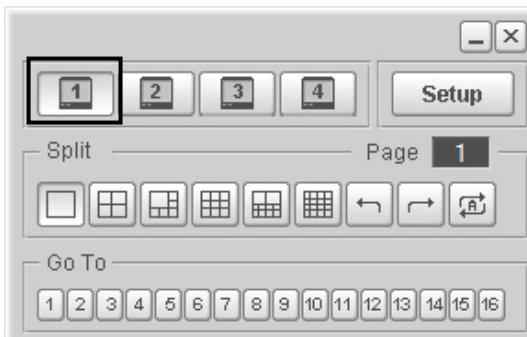

Port 1 : 1, 4, 6, 9, 10, 16 Splits

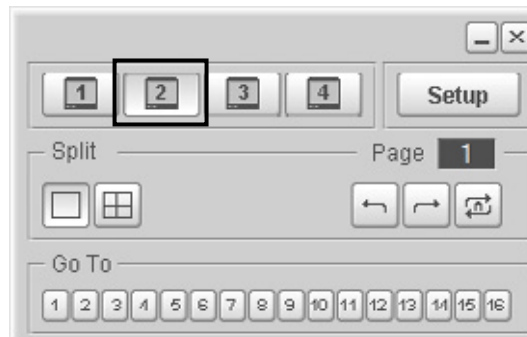

Port 2 : 1, 4 Splits

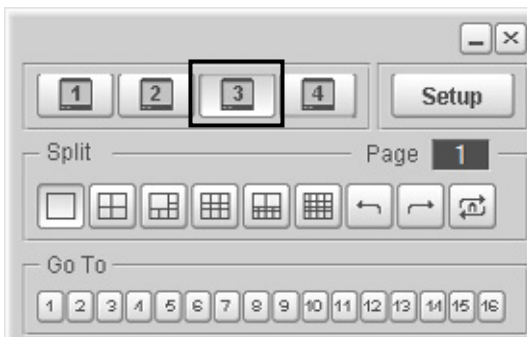

Port 3 : 1, 4, 6, 9, 10, 16 Splits

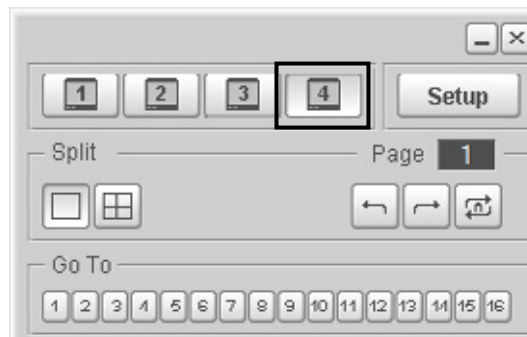

Port 4 : 1, 4 Splits

### 6-3. Menu

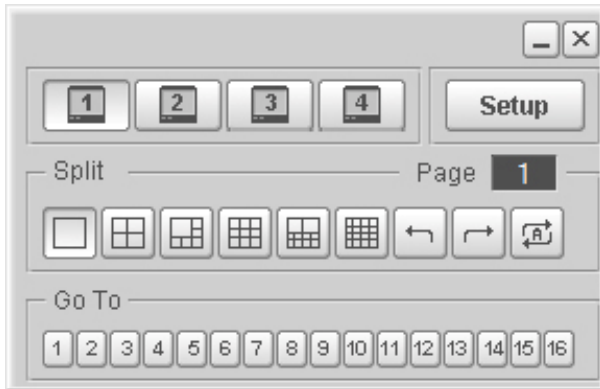

Main menu



TV-OUT port selection buttons.



TV-OUT Board setup button.



Split screen selection buttons.



Displays previous screen.



Displays next screen.



Enables auto switching.



Select one of these buttons to display the corresponding channel in a single view mode.

## 6-4. Setup

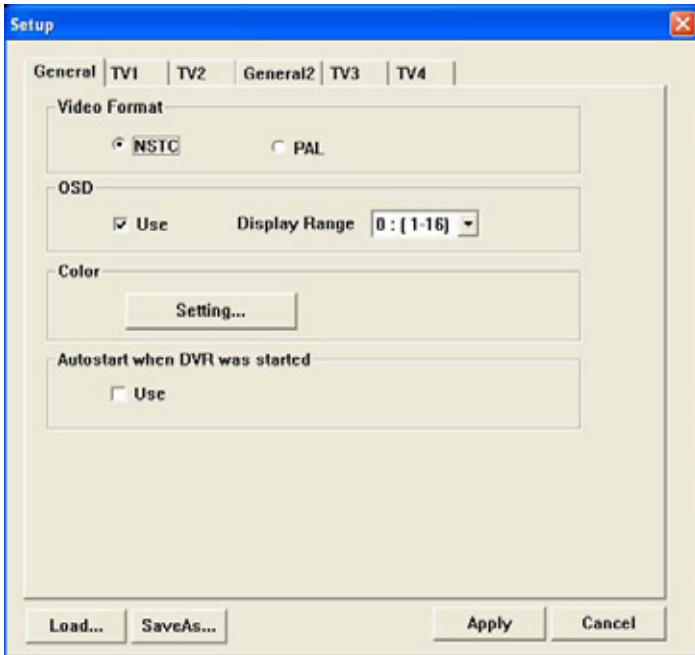

### 6-4-1. General

Video Format: Choose NTSC or PAL mode.

USE: Enable or disable the OSD.

Display Range: Select the OSD number (1~16 or 17~32).

Color: Click "Setting" to configure the color setting of TV-OUT Images as below.



Auto start when DVR was started: Set to Use to initiate auto switching when DVR Main software turns on.

Load : Load pre-configured user settings.

Save As : Save current user settings.

Apply : Apply current settings.

Cancel : Discard current settings.

### 6-4-2. TV1, TV2, TV3, TV4

TV-OUT port configuration

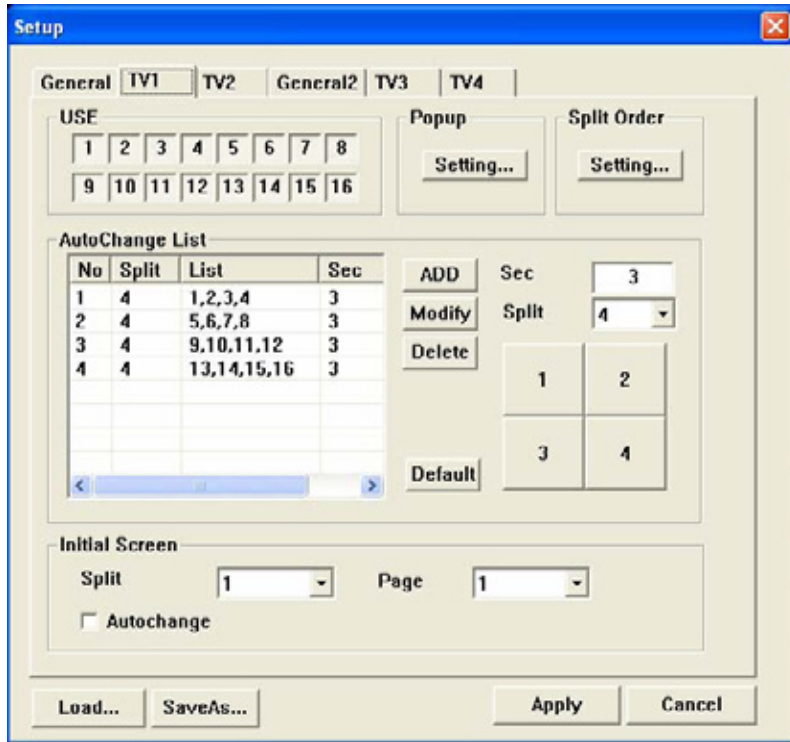

Select output channels for TV-OUT.

Inactivated channels will not be displayed on the TV-Out screen.



Click "Setting..." button to popup selected channel when an event is triggered.

No	Type	Cam/Sensor	Time	Split	camera list
3	All Event	3	10	4	1 4 7 11
1	Motion	1	5	1	1
2	Sensor	2	5	4	1,2,3,4
3	All E...	3	10	4	1,4,7,11

No : Event order list number.

Type : Select an event type (Motion, Sensor, Sensor & Motion)

Cam/Sensor : Select a channel to popup when the specified type of event is triggered.

Time : Set the duration of TV-OUT popup when an event is triggered.

Split : Choose popup screen between 1 split and 4 split

Camera list : Select channel to popup

Add : Add event configuration to the list

Modify : Modify configuration of the list

Delete : Delete configuration from the list



Click 'Setting...' to set up split channels when selecting split screen

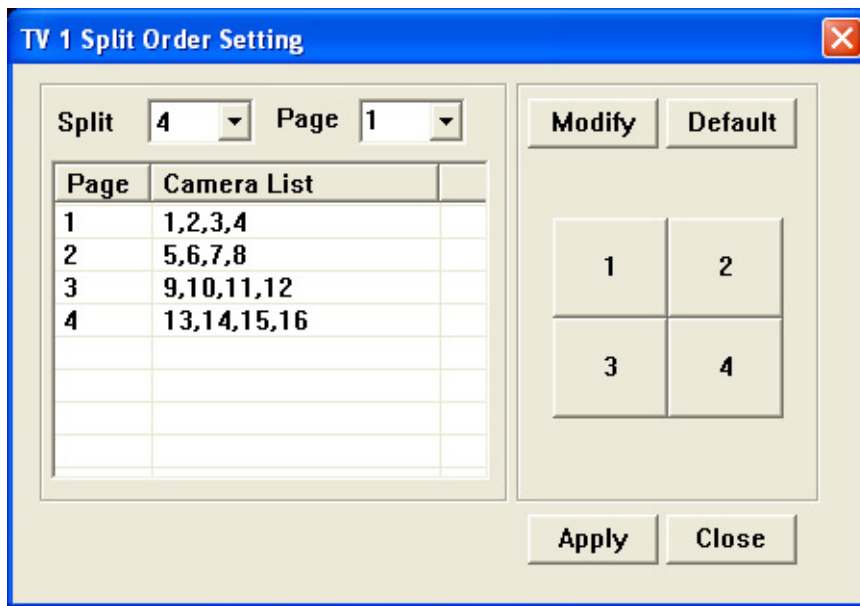

Split : Select split screen.

Page : Select page of the split screen.

After setting split and page number, click on split layout boxes on the right to change camera numbers.

**NOTE: Split order Setting is only applied when split screen modes are selected manually.**

**Auto Change mode will display screens according to the configuration of the Auto Change List.**

Auto Change list : Configure split screens and duration of the Auto Change mode.

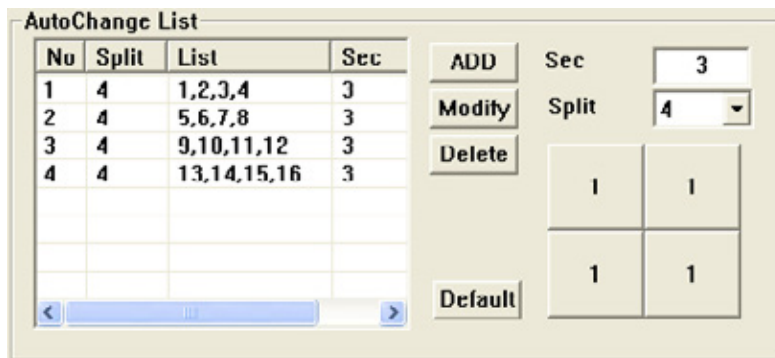

Auto switching will run according to the items registered on the list.

Add : Add to the list.

Modify : Modify an existing item.

Delete : Delete an existing item.

Default : Load factory default setting.

Sec : Duration for switching.

Split : Select split screens for switching.

Click split screens on the right to select channels.



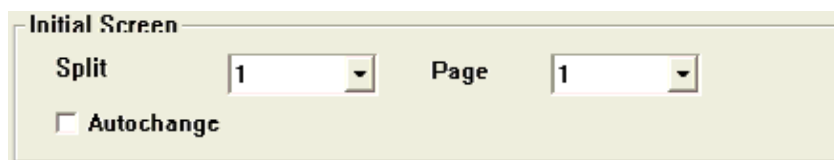

The image shows a configuration panel titled "Initial Screen". It contains two dropdown menus: "Split" and "Page", both set to the value "1". Below these is a checkbox labeled "Autochange" which is currently unchecked.

**Initial screen can be configured for a screen division, a predefined page, and auto switching.**

Split : Choose screen split.

Page : An option to choose the page selection among split screens.

Autochange: An option to choose auto switching mode as a start. (Automatically switches to set value due to registration under Autochange list)